

ChEn 273

Class 1

- Course Introduction
- Units and unit conversions
- Significant figures
- Process Flow Diagrams
- Stream variables



http://www.emersonprocess.com/home/news/resources/images/omv-refinery_hires.jpg

TAs are your friends!

Quiz: See TAs before next class!!!



NAME: Doug Parker
EMAIL: douglaspar@yahoo.com
OFFICE: 219 CB
HOURS: T Th 3-5 pm
MWF 4-5 pm

Laurie Hutchins Swensen
laurie.swensen@gmail.com
219 CB
MWF 9-10 am

Units of Force

System	Mass	Length	Time	Force	g_c	g	g/g_c
SI (System International d'unités)	kg	m	s	N	$1 \text{ kg}\cdot\text{m}/\text{s}^2\cdot\text{N}$	$9.807 \text{ m}/\text{s}^2$	$9.807 \text{ N}/\text{kg}$
CGS	g	cm	s	dyne	$1 \text{ g}\cdot\text{cm}/\text{s}^2\cdot\text{dyne}$	$980.7 \text{ cm}/\text{s}^2$	$980.7 \text{ dyne}/\text{g}$
FPS	lb_m	ft	s	poundal	$1 \text{ ft}\cdot\text{lb}_m/\text{s}^2\cdot\text{poundal}$	$32.17 \text{ ft}/\text{s}^2$	$32.17 \text{ poundal}/\text{lb}_m$
British (physics)	slug	ft	s	lb_f	$1 \text{ ft}\cdot\text{slug}/\text{s}^2\cdot\text{lb}_f$	$32.17 \text{ ft}/\text{s}^2$	$32.17 \text{ slug}/\text{lb}_m$
AES (American Engineering System)	lb_m	ft	s	lb_f	$32.17 \text{ ft}\cdot\text{lb}_m/\text{s}^2\cdot\text{lb}_f$	$32.17 \text{ ft}/\text{s}^2$	$1 \text{ lb}_f/\text{lb}_m$

Bottom line: $1 \text{ lb}_m = 1 \text{ lb}_f$ (under normal gravity), but 1 kg weighs 9.807 N !

Significant Figures

- **Addition/Subtraction:** Compare position of last significant figure relative to the decimal point. The position farthest left is the last permissible significant figure for the sum or difference.
- **Multiplication/Division:** The number of significant figures in the product or quotient is equal to the lowest number of significant figures of any of the numbers being multiplied or divided.

Bottom line: Be Reasonable!

Process Flow Diagram (PFD)

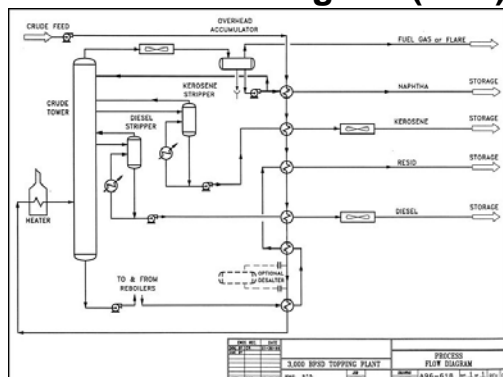

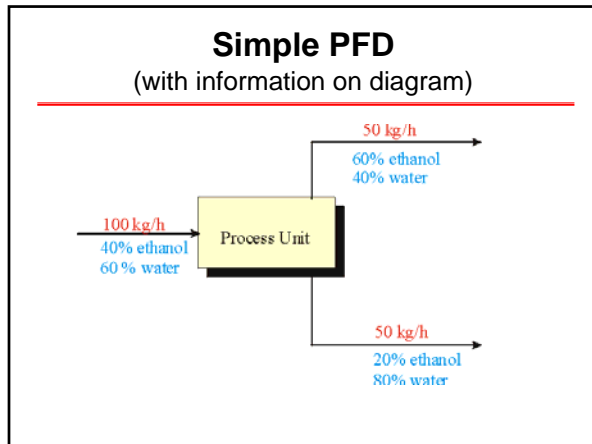

- ### Stream Variables
-
- **Extensive**- depend on the amount of material (e.g., flow rate)
 - **Intensive**- do not depend on amount (e.g., mole fraction or temperature)

 - Precision of numbers- significant figures
 - Numbers must have units!